

## 1.1 Input Characteristics

AC input voltage rating	220Vac
AC input voltage range	200Vac – 240Vac
AC input frequency range	47Hz ~ 63Hz
Input current	1.41A Max.
Input Power	150W Max.
Power factor	0.5 Min
Efficiency	85% Min



## 1.2 Output Characteristics

Output Voltage	12.0V
Rated load current	10.0A
MAX load current	12.0A
Rated Output Power	120W
Min. load current	100mA
Output Tolerance	±5%
Ripple and Noise	1000mVp-p

## 1.3 Performance Specifications

Line Regulation	±5%
Load Regulation	±5%

## 1.4 Protection Features

Over Current Protection	Output shut down with auto-recovery
Short Circuit Protection	Output shut down with auto-recovery
Over Voltage or Load Protection	Output shut down with auto-recovery
Over Temperature Protection	Auto-restart, 130°C (110 ~150°C)

## 1.5 Environments

Operating Temperature	-20°C to +50°C
Storage Temperature	-30°C to +70°C
Operating Humidity	20% to 90% R.H.
Storage Humidity	0% to 95% R.H.

## 1.6 Dielectric Withstand Voltage (Hi-Pot)

condition : non operating	
Test Point : primary to secondary	3.0KVac, 10mA, 3Sec

## 1.7 Insulation Resistance

condition : non operating	
Test Point : primary to secondary	Greater than 100MΩ at 500 VDC

## 2 Performance Evaluation

This session presents the test results of SMPS module up to data. Results on inrush current and safety test are not included and will be added when they become available. Overall, the module meets design specifications.

### 2.1 Input Characteristics

#### 2.1.1 Input current and Standby power

The module was tested at different input voltages (from 200Vac to 240Vac)

##### Standby power at min. load

Input Voltage	200V/60Hz	220V/60Hz	240V/60Hz
Pin (mW)	4.00W	3.90W	4.50W

##### Input current at full load

Input Voltage	200V/60Hz	220V/60Hz	240V/60Hz
Input Current (A)	1.50A	1.41	1.31A

##### Efficiency

Input Voltage	200V/60Hz	220V/60Hz	240V/60Hz
Input Power (W)	157.7W	157.3W	157.0W
Output Power (W)	142W	142W	142W
Power factor	0.54	0.52	0.51
Efficiency (%)	90%	90%	90%

### 2.2 Output Characteristics

#### 2.2.1 Line Regulation & Load Regulation

Input Voltage	Output Voltage (V)		
	Min Load	Nor. Load	Max Load
200V/60Hz	11.86V	-	11.82V
220V/60Hz	12.02V	-	11.82V
240V/60Hz	12.50V	-	11.82V

#### 2.2.2 Ripple & Noise

Ripple & Noise measure results

Input Voltage	Ripple & Noise (mV)		Remark
	Min Load	Max Load	
200V/60Hz	-	430mV	
240V/60Hz	-	400mV	

Note: Ripple & noise were measured at DC Cable end with a 0.1uF/50V ceramic cap connected in parallel with a 47uF/50V Electrolytic cap. Bandwidth was limited to 20MHz.

### 2.3 Protections

#### 2.3.1 Over Current Protection (OCP)

The power supply will shut down auto-recovery when output current exceeds up load 100%, and it should recover when the over current condition is removed.

### 3 load Characteristic Curve

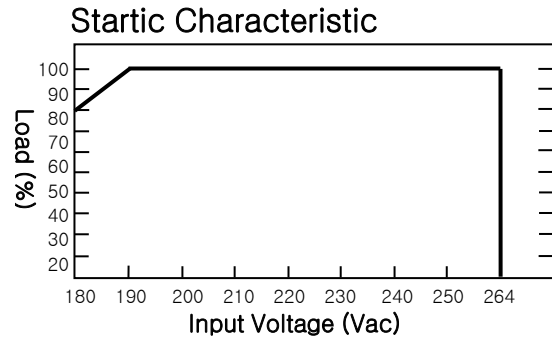
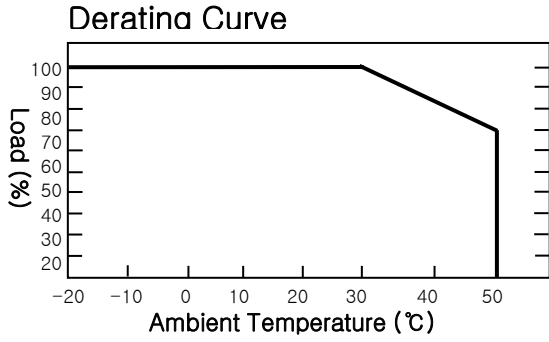

### 4 Block Diagram

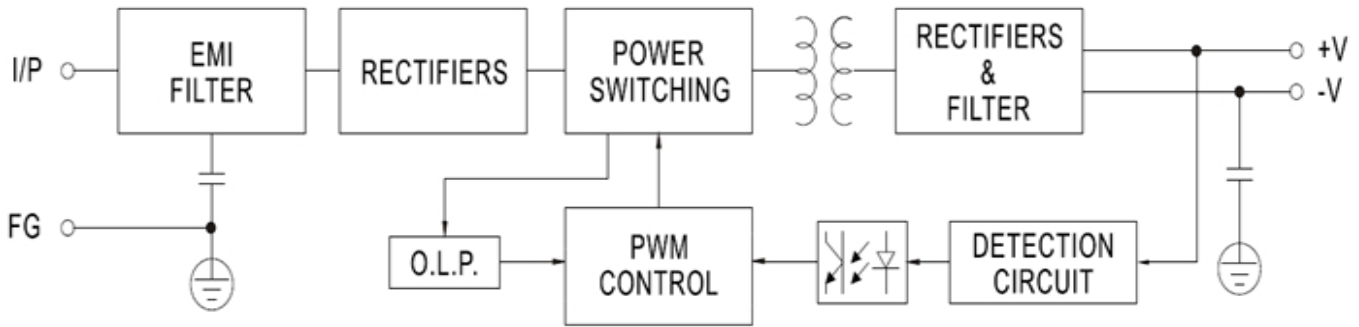

### 5 Case size

